

Two doors, left + right

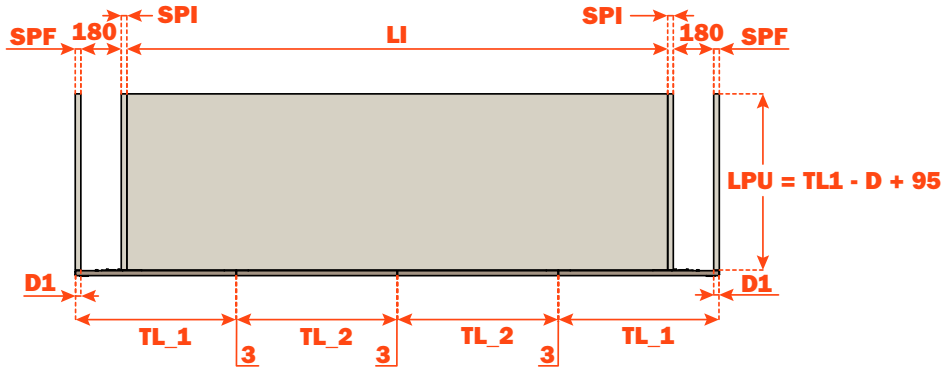

Single door, left

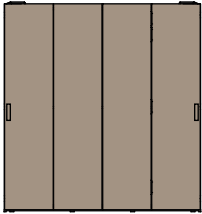
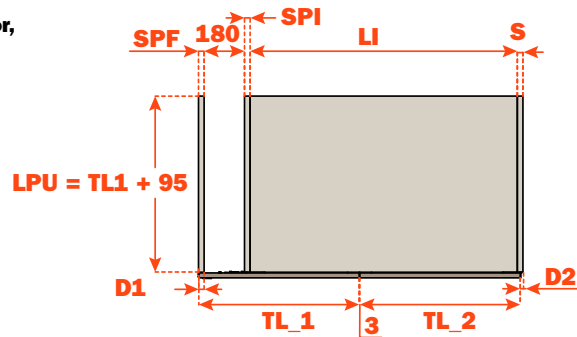
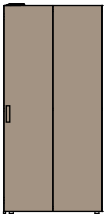

Single door, right

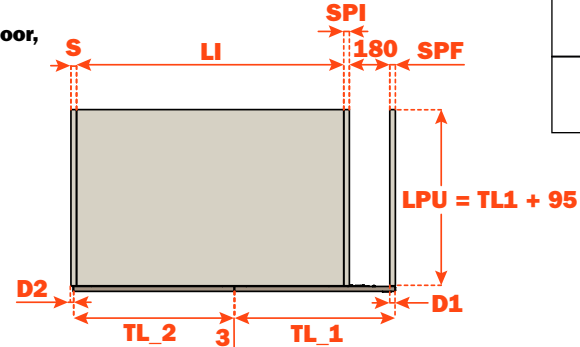

Front and side cover finish

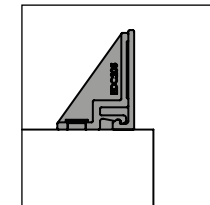
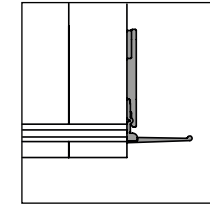

Maximum weight of two doors 50 Kg	
LHT	Total height of cabinet (mm)
SPC	Thickness of top panel (mm)
LHI	Internal height of cabinet (mm)
SPB	Thickness of bottom panel (mm)
LI	Total internal width of cabinet (mm)
S	Thickness of side panel (mm)
SPI	Thickness of central panel (mm)
TH	Height of door (mm) • max 2600 mm
TL1	Width of internal door • min 550 mm - max 850 mm
TL2	Width of external door • min 550 mm - max 850 mm
T	Thickness of door (mm) • min 18 mm - max 25 mm
D1	Coverage on side cover (mm)
D2	Coverage on side panel - only for single mechanism (mm)
LPU	Usable external depth of cabinet • min = $TL1 - D + 95$ mm
	Presence of side cover
SPF	Thickness of side cover (mm)

Contact name
Company
Date
Project
Notes

